



DATA SHEET

COESTRUSORI ORIZZONTALI, VERTICALI E UNIVERSALI  
HORIZONTAL, VERTICAL AND UNIVERSAL COEXTRUDERS

# COESTRUSORI COEXTRUDERS

## COESTRUSORI ORIZZONTALI HORIZONTAL COEXTRUDERS

| CARATTERISTICHE TECNICHE<br>TECHNICAL SPECIFICATIONS         |      | COEX 13                | COEX 22                | COEX 30                | COEX 38                |
|--------------------------------------------------------------|------|------------------------|------------------------|------------------------|------------------------|
| Motore C.a.<br>A.c. Motor                                    | kw   | 1,1                    | 1,85                   | 3                      | 7,5                    |
| N. giri vite<br>RPM                                          | kg/h | 0-240                  | 0-140                  | 0-145                  | 0-140                  |
| Diametro vite<br>Screw diameter                              | mm   | 14                     | 22                     | 30                     | 38                     |
| Lunghezza vite<br>Screw lenght                               | mm   | 240 (17D)<br>322 (23D) | 396 (18D)<br>506 (23D) | 540 (18D)<br>690 (23D) | 836 (22D)<br>950 (25D) |
| Capacità produttiva<br>PVC plastificato<br>Capacity soft PVC | kg/h | 0,5-4                  | 1-10                   | 2-20                   | 3-36                   |
| LxWxH                                                        | mm   | 1970x<br>1050x<br>600  | 1990x<br>1495x<br>600  | 2070x<br>1705x<br>600  | 2290x<br>2075x<br>600  |
| Peso<br>Weight                                               | kg   | 200                    | 280                    | 340                    | 420                    |

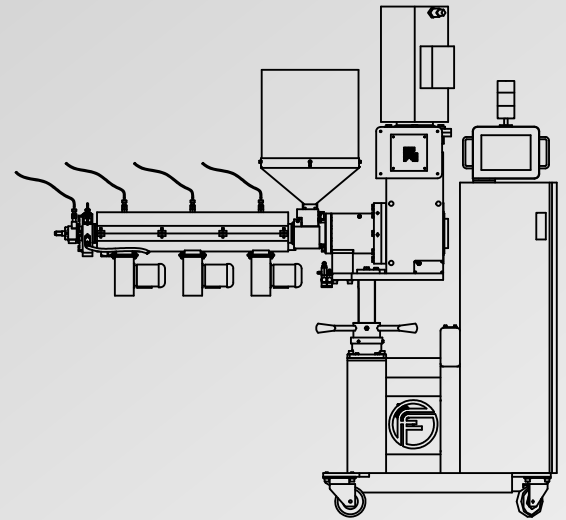

## COESTRUSORI VERTICALI VERTICAL COEXTRUDERS

| CARATTERISTICHE TECNICHE<br>TECHNICAL SPECIFICATIONS         | COEX<br>22/V           | COEX<br>30/V           | COEX<br>38/V           |
|--------------------------------------------------------------|------------------------|------------------------|------------------------|
| Motore C.a. (Kw)<br>A.c. Motor (Kw)                          | 1,85                   | 3                      | 7,5                    |
| N. giri vite<br>RPM                                          | 0-140                  | 0-145                  | 0-140                  |
| Diametro vite<br>Screw diameter                              | 22                     | 30                     | 38                     |
| Lunghezza vite<br>Screw lenght                               | 396 (18D)<br>506 (23D) | 540 (18D)<br>690 (23D) | 836 (22D)<br>950 (25D) |
| Capacità produttiva PVC plastif.<br>Capacity soft PVC (Kg/h) | 1-10                   | 2-20                   | 3-36                   |
| LxWxH                                                        | 2550x<br>1100x<br>900  | 2550x<br>1100x<br>1100 | 2700x<br>1600x<br>1400 |
| Peso<br>weight                                               | 610                    | 630                    | 670                    |

## COESTRUSORI UNIVERSALI UNIVERSAL COEXTRUDERS

| CARATTERISTICHE TECNICHE<br>TECHNICAL SPECIFICATIONS         | COEX<br>22 V/O         | COEX<br>30 V/O         | COEX<br>38 V/O         | COEX<br>45 V/O           |
|--------------------------------------------------------------|------------------------|------------------------|------------------------|--------------------------|
| Motore C.a. (Kw)<br>A.c. Motor (Kw)                          | 1,85                   | 3                      | 7,5                    | 15                       |
| N. giri vite<br>RPM                                          | 0-140                  | 0-145                  | 0-140                  | 0-100                    |
| Diametro vite<br>Screw diameter                              | 22                     | 30                     | 38                     | 45                       |
| Lunghezza vite<br>Screw lenght                               | 396 (18D)<br>506 (23D) | 540 (18D)<br>690 (23D) | 836 (22D)<br>950 (25D) | 1125 (25D)<br>1359 (30D) |
| Capacità produttiva PVC plastif.<br>Capacity soft PVC (Kg/h) | 1-10                   | 2-20                   | 3-36                   | 5-50<br>10-90            |
| LxWxH                                                        | 2550x<br>1100x<br>900  | 2550x<br>1100x<br>1100 | 2700x<br>1600x<br>1400 | 3500x<br>2600x<br>1600   |
| Peso<br>weight                                               | 650                    | 670                    | 1020                   | 1500                     |